

Horizontal Line Marker

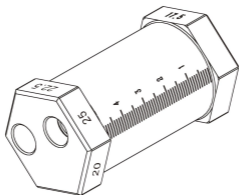

1. Technical Parameter

The vertical height between the hole center and each plane is shown in the figure (unit: mm)

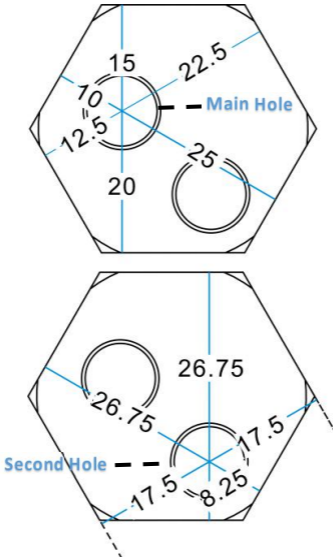

2. How to Use

(1) When viewed from the side with scales, you can see a rubber ring in the hole. This is the hole which you will use.

Main hole scales : 10 / 12.5 / 15 / 20 / 22.5 / 25

Second hole scales : 17.5 (8.25&26.75 not frequently used, so they are not marked.)

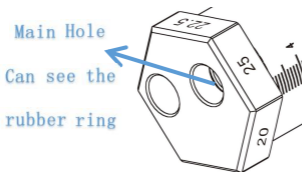

(2) Vertical height measurement of the frame ;

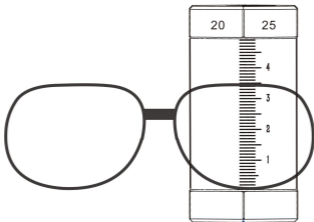

(3) Confirm the scale you want to use and find the corresponding hole position. Insert the thin head of the marking pen into the hole from the side without the rubber ring.

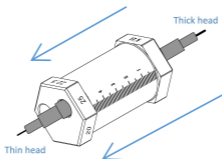

(3) Scale up, the number shown represents the vertical height of the hole center (pen core) at this time, and you can switch the scribe height by rolling this unit. (If you need to use 17.5, please insert the marking pen into the second hole)

(4) Put the Frame and the MARKER on a horizontal table, then do the scribe.

